

RAK-APX-EARS Instructions

Rackmounting kit for APx series audio analyzers



Note: this kit is not compatible with APx511 or APx515 analyzers.

Item	Parts List	Part No.	Qty
(1)	screw, # 8-32 x 1/4	5114.1108	4
(2)	screw, # 10-32 x 5/16	5115.4110	8
(3)	Rack Ear, Right	7170.0014 r000	1
(4)	Rack Ear, Left	7170.0015 r000	1
(5)	4" handle, threaded	7320.0006	2
	(APx chassis, shown for reference)	(not included)	

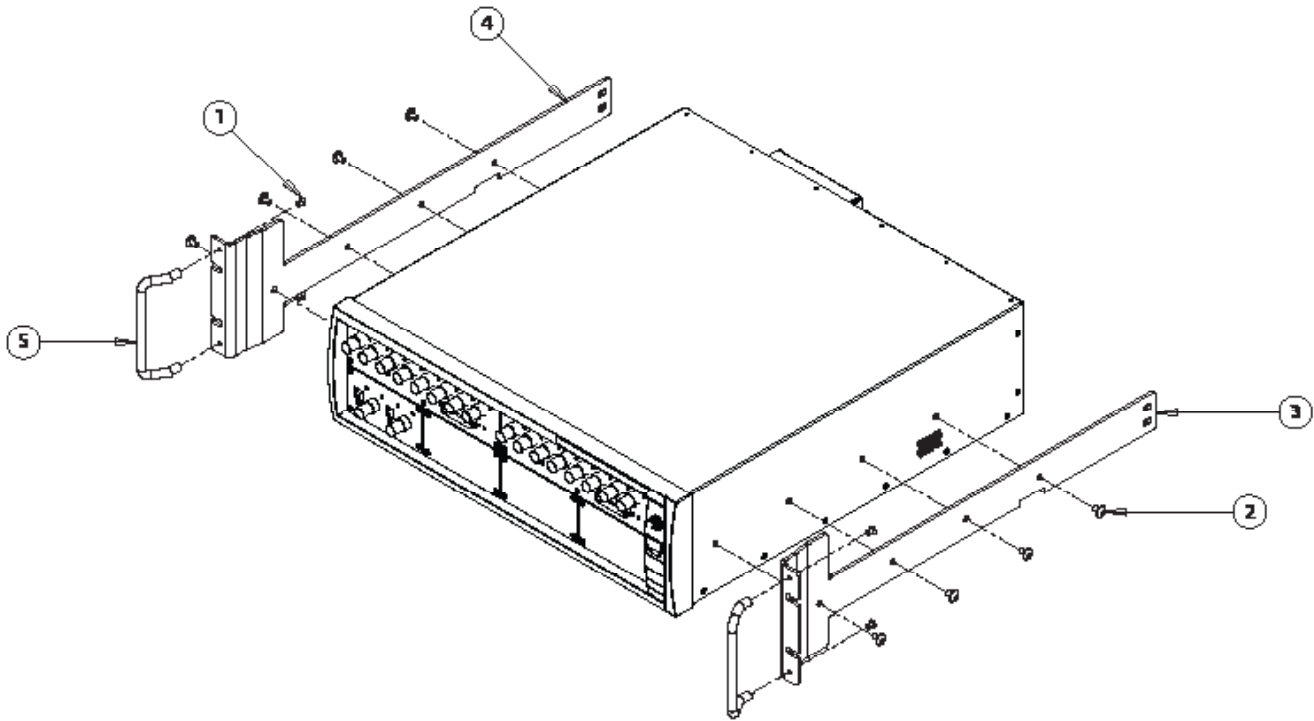

Instructions

1. Remove the strap handle (if fitted) from the APx chassis. Remove the four feet if necessary for clearance.
2. Mount a handle (5) to each of the rack ears (3) and (4), using the # 8-32 x 1/4 screws.
3. Mount the right rack ear / handle assembly (3) to the right side of the APx chassis, using 4 of the # 10-32 x 5/16 screws.
4. Mount the left rack ear / handle assembly (4) to the left side of the APx chassis, using 4 of the # 10-32 x 5/16 screws.
5. Secure the APx / rack ear assembly to the mounting rails of a standard 19" equipment rack, using 4 # 10-32 screws.
This may require the assistance of a second person.



5750 SW Arctic Drive
Beaverton OR 97005
1-800-231-7350
sales@ap.com
www.ap.com